

**Building Information Modeling for Masonry
Phase II Project**

**Project 1, Masonry Unit Model Definition
Pankow Foundation Grant RGA#03-13**

Report 2

Masonry Unit Database

delivered to

**Charles Pankow Foundation
in support of the
Building Information Modeling for Masonry Initiative (BIM-M)**

**Georgia Institute of Technology
School of Architecture
Digital Building Laboratory**

**T. Russell Gentry, PI
Charles Eastman, co-PI
Shani Sharif, Graduate Research Assistant
Tyler Witthuhn, Graduate Research Assistant
Jeff Elder, Interstate Brick
Project Manager**

13 August 2014

1. Executive Summary

This report provides a detailed description of the proposed Masonry Unit Database or MUD, developed by Georgia Tech for the Building Information Modeling for Masonry (BIM-M) Initiative. The content and organization of the database has been derived based on an analysis of the masonry industry from the perspective of major stakeholders in the industry, including masonry suppliers, purchasers, design professionals, contractors, and masons. In addition, the database has been structured to complement existing classification schemes for masonry materials. A detailed description of masonry material workflows and classifications can be found in the first report from this project.¹ A brief description of stakeholders and their requirements for information can be found in Section 3 of this document.

Because the MUD is intended to facilitate the development of new BIM and other software applications for the masonry industry Georgia Tech team has reviewed current applications and their use of masonry data (see Section 5).

Section 6 of the report contains a detailed description of the database, based on the enhanced entity-relationship (EER) model. This model is essentially a graphical view of the schema that will be implemented as a relational database for the first version of the MUD. Future versions of the MUD may be implemented as a cloud database.

This report is an interim deliverable from the Georgia Tech team. At this time, it is critical that we receive feedback as to the organization and content of the proposed MUD. In the fall of 2014 we intend to implement the database with a small selection of masonry units – in an SQL data management system such as MySQL, and we would like for this database demonstration to be as comprehensive as possible. Therefore, a review of the data model by the current BIM-M community, and especially masonry suppliers and software providers, is critical at this time.

2. Background

In January 2013, the Digital Building Laboratory (DBL) at the Georgia Institute of Technology completed a roadmap to bring Building Information Modeling (BIM) to masonry². This overall project involves industry trade associations and stakeholders from throughout the masonry industry, BIM and other software providers to the AEC industry, and subject matter experts. The roadmap outlines three phases of research and implementation. The current Development Phase (Phase II) focuses of further elucidating the workflows and software requirements for BIM for masonry, and the completion of seminal projects that will underpin the BIM-M software specification.

¹ <http://www.bimformasonry.org/pdf/gt-pankow-report-rga-3-13-masonry-unit-workflows-3-march-2014.pdf>

² See: <http://www.bimformasonry.org/pdf/a-roadmap-for-developing-and-deploying-building-information-modeling-bim-for-the-masonry-industry.pdf>

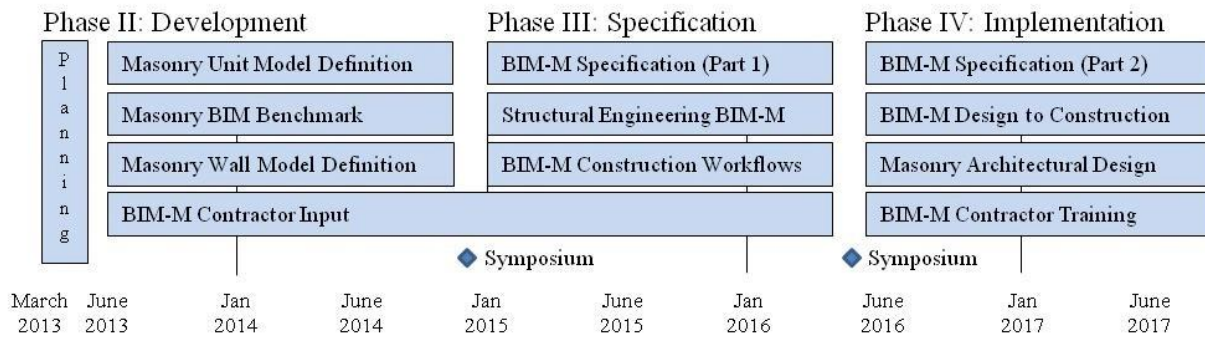

Figure 1. Proposed development and implementation plan from the BIM-M Roadmap.

The first project in Phase II of the Building Information for Modeling (BIM-M) Initiative is the Masonry Unit Model Definition (MUMD). This first Phase II project focuses on the development and prototyping of a data model for masonry units. In this project, the Georgia Tech team is working with the BIM-M initiative’s Material Supply Working Group to develop requirements for digital representation of masonry units. The project is denoted the Masonry Unit Model Definition and the primary deliverable is the proposed structure for and operation of the Masonry Unit Database or MUD. The goal is to develop a data model to capture all of the geometric and non-geometric information needed to select, specify and purchase masonry units. In the future, we envision that the MUD unit will act as a basis for digital product catalogs, web-based product selection applications, masonry e-commerce, cost-estimating and integrated with the BIM applications to be developed later in overall initiative. It is important to note that the MUD is intended to fulfill two distinct but critical roles: (1) to act as a data repository for the geometric description of the masonry units including its nominal and specific geometry as well as its color and texture and (2) to capture descriptors needed to facilitate business and engineering processes, such as cost estimating, availability, unit of order, specifications met, etc. At this time, the first role is the primary focus of MUD development, and business processes must be put in place in order to establish the data required to fully support the second role.

The MUD can be compared to the database of structural steel shapes, created by the American Institute of Steel Construction (AISC) that forms the data foundation for structural steel modeling and fabrication software. The added complexity in the masonry industry is that units are not standardized or classified across industry segments in the way that steel shapes are, and so for example there are many specific unit geometries that may meet a given requirement, and the MUD must be structured in a way so that it can be queried for nominal geometries, and not just specific geometric attributes.

3. Stakeholders

One means to assess the information requirements for the MUD is to characterize the stakeholders in the masonry design, procurement and construction process and to relate these stakeholders to their information requirements. These information requirements are tied to their details regarding their workflows, and these workflows have been described in detail in our previous report¹. An overall view of stakeholders and their access to the MUD is provided in Figure 2. In the text below, we briefly describe the stakeholders and their relationship to the data stored in the MUD.

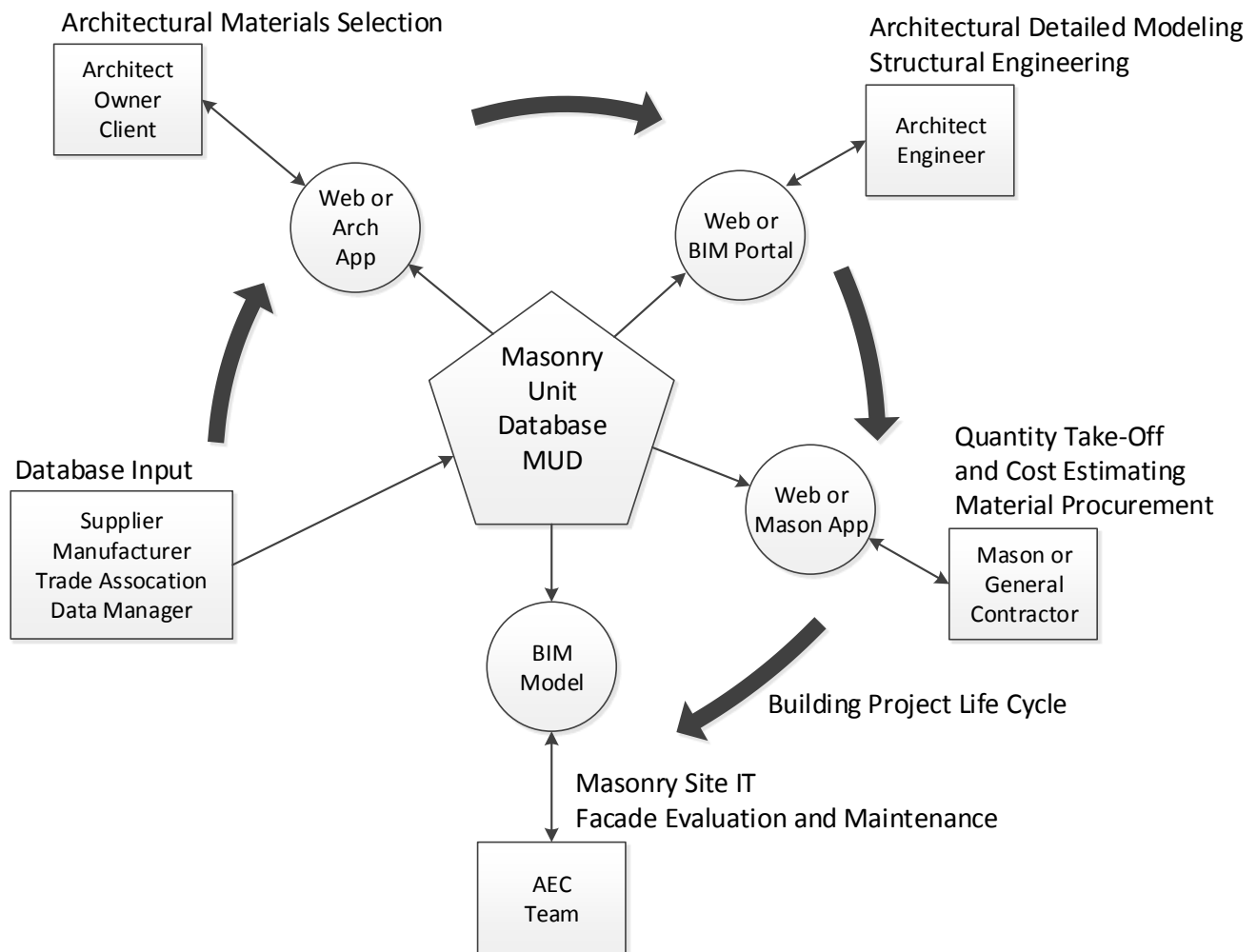

Figure 2. Stakeholder and workflow model for the MUD.

3.1. Masonry Manufacturer

The masonry manufacturer is primarily a producer of masonry units and in this role is likely to author much of the information into the MUD. The masonry supply chain is not homogeneous – in some cases the masonry manufacturer markets and sells masonry units directly to contractors, and in other cases the manufacturer sells to a supplier – who stocks and supplies the units to contractors.

3.2. Masonry Supplier

In the context of this report, a masonry supplier is a vendor of masonry units but does not manufacture the units. Depending on the nature of the supply chain, the masonry supplier may be responsible for inputting information into the MUD.

3.3. Trade Association

The clay and concrete masonry market segments produce many *generic* masonry units³ meeting a nationally recognized specification that may include descriptions of geometry and physical properties. They also produce *specified* units which may be standardized in shape but custom only in terms of color and texture. In the case of these units, such as the ubiquitous 8x8x16 CMU (190x190x390 CMU in Canada) and the modular brick, it may be that industry trade associations that support the clay and concrete masonry industries will populate the MUD with these units – and that an attribute in the database will flag that the unit is generic, that is, its geometry and properties are correct in the database, but that the fields associate with cost, supplier, manufacturer, stocking, etc. are left blank. The generic units will be acceptable for early-stage design and BIM instantiation, but will not work downstream for cost-estimating, for example.

3.4. Data Manager

The “data manager” stakeholder is speculative at this time but represents a business entity who is responsible for the collection, validation, input and maintenance of the data in the MUD. If the MUD grows to support electronic commerce and construction information technology, in addition to its clear role as a data repository for BIM, then the need for reliable data is clear. Given the range of company sizes in the masonry supply industry, from small companies with one plant to vertically-integrated companies with worldwide operations, it is clear that not every company will have the resources to maintain their MUD data internally. Therefore, it is suggested that the role of the data manager be thoroughly explored as the MUD is implemented. The masonry supplier industry trade associations may take on this role initially.

3.5. Building Owner/Client

The building owner or client may be interested in reviewing masonry materials that complement existing building stock. Or, in residential construction (which is not the specific focus of BIM-M), the owner/client may be directly involved in picking the masonry materials. For this stakeholder, the primary information that the stakeholder will be looking for is appearance, price, and availability.

3.6. Architect

The architect will interact with masonry unit information in multiple stages of the design process, with the three most important being: materials selection, detailed design, and construction documents (including specification writing). These workflows and interactions are described in detail in our previous report. The architect requires a full range of information regarding masonry units including aesthetic, geometric, physical properties, and price.

3.7. Structural Engineer

The structural engineer is primarily concerned about the geometric and physical properties of the masonry units. In many cases, the unit properties must be considered along with the properties of allied materials (grout, reinforcement) to develop overall properties of masonry walls. The intent is to include as much

³ *Generic* units are described as those units meeting a specification that freely allows for product substitution between suppliers. Related to the term *generic* units are *specified* units, which cannot be substituted between suppliers without permission from the design team, and *custom* units, which are manufactured specifically for the building project.

unit-level property data as necessary, so that structural design can be completed with information stored in the MUD.

3.8. Energy Analyst

The energy analyst also requires geometric and physical property data – and builds thermal characteristics of masonry walls from the thermal resistivity, surface characteristics, and density of the masonry units.

3.9. Mason Contractor

The mason contractor, like the architect, needs the complete range of masonry unit data depending on the phase of the project. In many cases the mason contractor may need appearance data in order to match existing units or to compare between units for product substitution. The mason contractor will also need information about coverage (that is, how many units are required per unit area of wall), price and availability to prepare cost estimates. It may be that the pricing data stored in the MUD will be valid only for preliminary pricing, and so workflows will be required that allow for cost-estimating to be updated during the QTO/Cost Estimating process.

3.10. General Contractor

The general contractor may have the same data needs as the mason contractor, but to a less detailed level. Many sophisticated GCs who practice “Virtual Design and Construction” are building high level of development (LOD) BIM models and these GCs are likely to access the geometric parts of the MUD in order to have the geometry of the masonry units. The concept of Levels of Development (sometimes referred to as Levels of Detail) or LOD in a BIM model come from idea of increasingly complex level of description of the elements in a building model as the model goes from LOD 100 (the most schematically described building model populated with few objects) to LOD 500 (a BIM model with an almost complete level of description including detailed objects and field verification of as-built information).

3.11. Software Supplier

Software suppliers may mine the MUD in order to convert the open-source geometric information found in the database into their proprietary graphic formats. These software links to the MUD are discussed in greater detail in Section 5, below.

4. Scenarios of Use

The scenarios of use can be thought of as high-level workflows without the detail of data exchanges and data formats. There are many scenarios of use for the MUD, but four major scenarios are highlighted here. As BIM-M stakeholders review the proposed data schema described in Section 6 below, they should think of their own scenarios of use and ask the question: “Is the information I need about masonry units available in the database?” If the answer is NO, then we need to hear from you about what is missing.

4.1. Material selection for aesthetics

Material selection for aesthetics involves primarily the shape, color and texture of masonry units. There are many nuances here, and in commercial construction, the selection of masonry units and associated materials (accent stone, grout, flashing) often involve the production of physical sample boards or mock-ups because digital information does not do a good job of demonstrating or promoting the “patina” that comes with masonry. In order to promote the use of the MUD for aesthetic decision making, the database

will provide for storage of graphic bitmaps representing images of the finished faces of the units. The database will accommodate⁴ multiple instances of the same view, so that in an array of these randomized images will show the approximate variation across the range of units. See also the discussion of the Masonry Designer software, in Section 5, below.

4.2. Importing geometry into BIM or CAD

In many cases, an architect (or any stakeholder attempting to create a high level of detail model) will want to insert the 3D or 2D geometry of the masonry unit into a BIM or CAD model. The database will accommodate this by storing both 3D models and 2D drawings of the required graphic information. Common file formats for these models/drawings are DXF (AutoCad drawing exchange format), RVA (Revit), Parasolid, and SketchUp Component. We believe that if these four file types are stored, we will have almost complete coverage in the BIM/CAD world.

4.3. Wall material property determination

A structural engineer or energy analyst will need to access the MUD in order to calculate structural or thermal properties of masonry assemblies (walls). It is for this reason that the geometric properties of generic masonry units are stored as descriptors instead of as 3D solid models, and so, for example, the face shell thickness of a block can be determined directly from the database, without having to load a BIM model and query the model for that thickness. In some situations, this query will be completed through a web application that provides the information to the engineer, but it will also be easy to tie the MUD to Excel or other programs so that wall properties can be calculated automatically using third-party programs that query the MUD.

4.4. Determining material availability

A final scenario for the MUD is the determination of material availability. This is a typical application of databases that manage inventory, but that functionality has not been envisioned for the MUD, because at this time the MUD is not seen as a full ERP (enterprise resource planning) database for internal business processes. Nevertheless, the MUD can be a first step for a masonry customer in determining whether a given masonry unit is stocked or custom, what the minimum order quantity is likely to be, and whether it is produced within a given region of the country (which is often of interest in projects seeking a LEED rating).

5. Software Applications and their Access to the Masonry Unit Database

In this section, existing software applications that access masonry unit information are briefly reviewed, and their potential linkage to the MUD is discussed. It is important that the development of the MUD facilitate, and not hinder, the advancement of these software programs. Therefore, the review of the proposed data model by these software vendors is critical in moving ahead with the MUD. Many software programs already use internal data models that include custom coding systems and masonry unit IDs. Many contain their own pricing or other data which is much more sophisticated than required for the MUD. The MUD should be expanded where necessary to accommodate these programs, but some consolidation of data schemes may be necessary if one data model (the MUD) is going to accommodate all masonry units.

⁴ When we say that the MUD “accommodates” or “stores” images or views or files, what is likely is that that the database will store a link to that file, instead of containing the bitmap or file itself. A naming convention should be developed so that it is clear from the file name the information stored in the given file.

Note that the review here is not comprehensive – the applications discussed are meant to be illustrative of the software which is in use in the AEC industry today. In addition, the comments provided here are based on our understanding of the software applications from marketing literature and are not based on comprehensive knowledge of the internal operation of the software.

5.1. Masonry Designer

Masonry Designer is a software program used primarily in the brick masonry industry to demonstrate the aesthetic properties of masonry. It uses images of bricks in various bonding patterns and with various grout colors to aid in masonry selection. It allows for the development of custom two-dimensional brick patterns. Brick vendors that do not use Masonry Designer often have web-based tools or other virtual “sample board” generators that fulfill this function. For example, Acme Brick has an additional add-in to Autodesk Revit that creates a Revit family from the Masonry Designer palette built by the user.

5.2. Tradesmen’s OS3DE

Tradesmen’s is a quantity take-off and cost-estimating tool tailored specifically for the mason contractor. Because of its strong graphical interface, it has also been used for project planning and even project conception. At this point, Tradesmen’s focuses on the mason contractor and its internal data structure allows the contractor to keep historical pricing data and develop rules for the quantity estimation of masonry accessories such as mortar, grout, rebar, etc. Tradesmen’s will clearly benefit from access to the MUD, but the Georgia Tech team will need substantive feedback to see what can and cannot be contained with the general purpose data model proposed for the MUD, which is not focused on cost estimating. And so, for example, at this time we only have one cost number included in MUD (cost per unit) and one attribute for QTO (number of units per unit area of wall).

5.3. CADBLOX

CADBLOX is a masonry detailing tool used primarily in the concrete masonry industry for detailing concrete block walls with a large number of special units – usually with appearance grade concrete masonry units (CMU). The program was originally developed for the Trenwyth line of CMU, but is currently being expanded into other masonry types. The software is currently marketed as part of a service, and not as a stand-alone tool for use by architects, engineers and mason contractors. CADBLOX as it exists is the closest application to a LOD 350 or 400 BIM tool for masonry to date, as it provides a fully 3D model of the masonry walls, with each unit instantiated. Because CADBLOX was developed for special units with complex geometry, it should be easily adapted to read geometric information from the MUD.

5.4. Autodesk Revit

Autodesk Revit is the market leading BIM authoring tool in North America. It is widely used by architects, structural engineers and general contractors. In the current version of Revit, masonry units are not defined. Instead, masonry walls are defined as generic walls containing masonry layers. The masonry walls are identified via a “hatch” pattern but this pattern is not aligned with the masonry coursing nor does it recognize how masonry is coordinated at corners and openings. Until the underlying infrastructure of Revit changes, the best way to bring masonry into Revit is through the generation of Revit families for download by architects, as is currently done by many brick and appearance-grade CMU suppliers.

5.5. Bentley Ram Elements

Bentley Ram Elements is one of the few general purpose structural engineering analysis and design programs that explicitly include the capability of analyzing and designing masonry walls. In addition to the shell finite element analysis used to determine the in-plane and out-of-plane forces in the masonry walls, the application includes a masonry module and detailing module that allows for placement of openings and detailing of the reinforced masonry walls. The program requires the input of basic masonry wall properties but most of these are tied to the compressive strength of the masonry wall assemblage ($f'm$). Therefore, there is little to be gained from tying the structural analysis package to the MUD.

5.6. BIM Portals

BIM portals are aggregators of BIM information which can be searched and accessed from the web for pre-configured BIM objects, including masonry units and masonry walls. Current BIM portals⁵ include for example Autodesk Seek, SmartBIM, Arcat, RevitCity. The business model for BIM portals is to be paid to host the data of building product companies, and to provide information on the use of these models back to the these companies. Ultimately it may be one or more BIM Portals that agree to host the MUD, which will provide a common interface for web access to the MUD. In the fall of 2014, the Georgia Tech team will begin discussions with BIM Portal providers to gage their interest in hosting the MUD on a trial basis.

6. Database Organization

In the section below, the organization of the masonry unit database is described in detail. The section begins by providing a motivation for the organization of the database, and goes on to describe the overall entity-relationship model for the database. Finally, the section details each of the attributes to be contained in the relational database tables. A more compact view of the data schema, without the narrative, is provided in Appendix 1.

6.1. Engineering Units Representation in the Database

Many of the attributes will have engineering units associated with the properties (e.g., pounds, inches, psf). At this time, we recommend that the initial database values are input in units that agree with standard U.S. practice. This means that units will not be dimensionally consistent, as we typically specify strength in pounds per square inch (psi) but areal coverage in number of units per square foot. We recognize that the database may be used outside of the United States – and Canada is one of the partners in the BIM-M initiative. For metric output, it is possible to use derived attributes – that is, to have metric data calculated based on rules as opposed to having a completely separate metric database. This could be made transparent to the user. All the user would have to do is to check a “metric user” flag when they entered the database portal.

The other option is to have completely separate entries into the database for units sold in Canada. This may be required because of the difference between “hard metric” and “soft metric” conversions. Many Canadian units, for example, are 390 mm. In a soft metric conversion, a 15 5/8 inch unit dimension would be translated as 397 mm. In a hard metric conversion, the results of the conversion

⁵ Masonry suppliers are encouraged to visit these web portals and perform searches on them with the following questions in mind: Are your products featured? Do the keyword searches bring up the products you would expect? Is the product information provided correct?

might be made more rational, and the unit dimension might be given as 400 mm (or 40 cm). It is difficult to develop an algorithm to make hard metric conversions.

Though it adds complexity, it seems that both options may have to be considered, because, in some instances, there are masonry units made according to U.S. standard practice which are sold into Canadian and other metric markets, so a soft metric conversion is proper. In other cases, tooling is made specific to Canadian and other metric markets, so a hard metric conversion is appropriate.

6.2. Role of Classification

The first step in any database design process is requirements collection, analysis and classification. The detailed data is gathered from available resources and prospective database users. In addition to data requirement specification, the functional requirements and transactions for the retrieval and update of database also have to be identified. In the next step, a conceptual schema for the database with a high-level conceptual data model has to be created. For MUD, we have acquired entity-relationship model (ER model) that has the ability to describe in detail the entity types, relationships, and constraints of masonry units. Conceptual schema is easier to understand and communicate with nontechnical users, as concepts do not represent implementation and storage details. Readability by nontechnical users is an important aspect that ensures the complete identification of users' data requirements and prevention of any possible requirements conflict. In addition, in conceptual schema design phase the ER model operations can be acquired to determine the high-level user queries and operations.

6.3. Conceptual Schema Framework

At this level, we represent the related and required data to masonry units in an entity-relationship model (ER model), a high-level abstract method of organizing data to be later be implemented in a database application (i.e. a particular database and the associated programs that implement the database queries and updates). The ER model describes data as *entities*, *relationships*, and *attributes* (see Figure 3).

Entity, the basic object represented in ER model, represents a *thing* in the real world with an independent existence, an object with a physical or conceptual existence. Each entity is described with particular properties that are called the **attributes** of the entity. Any particular entity will have value for each of its attributes, which are the major part of the data stored in the database. Different types of attributes in the ER model are: *simple* versus *composite*, *single-valued* versus *multivalued*, and *stored* versus *derived*. In ER model, **relationships** represent references of entities types to each other. In other words, a relationship defines a set of associations among entities.

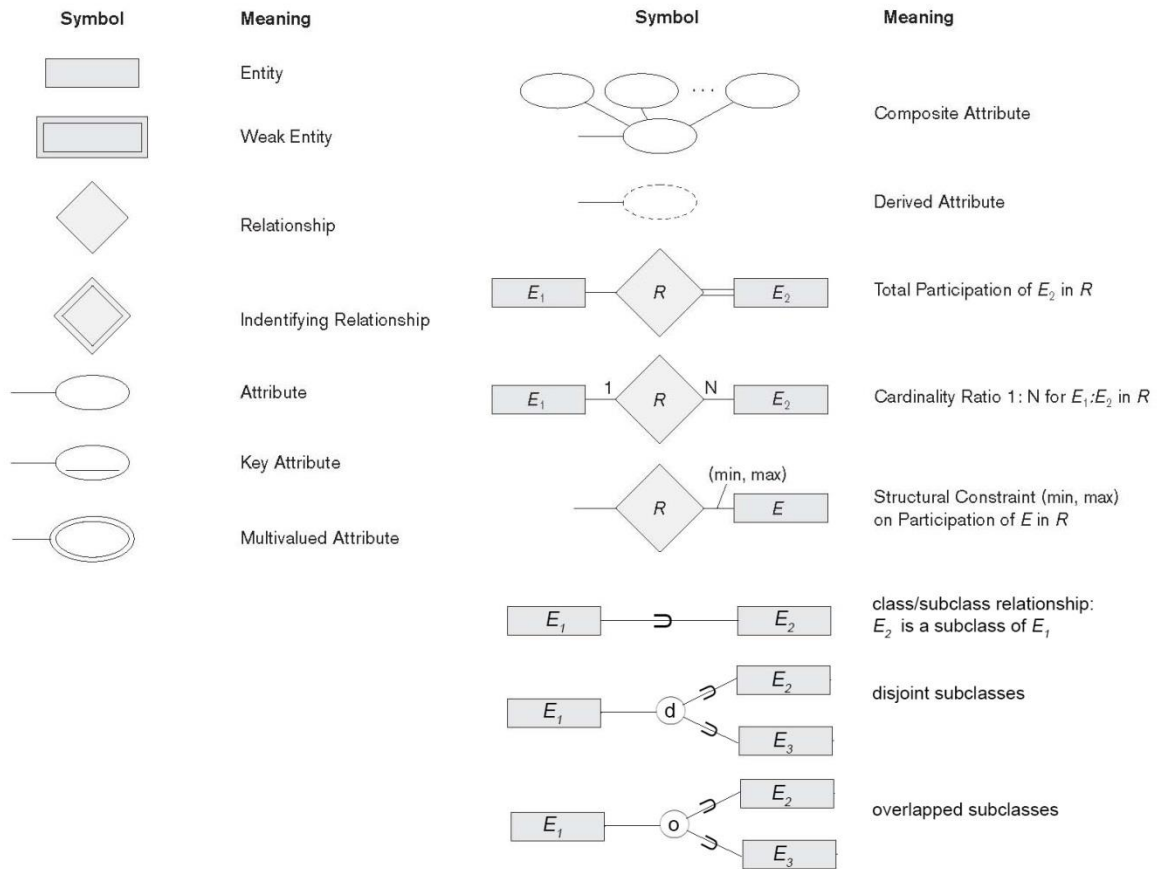

Figure 3. Summary of the notation for EER (Enhanced Entity Relationship) diagrams

In this project, we used the Enhanced ER (EER) model which is more suitable for newer applications of database technology including databases for design and manufacturing (CAD/CAM). EER model has additional semantic data modeling concepts incorporated into the ER conceptual data model. Among these concepts are *class/subclass relationships* and *type inheritance*. In a **superclass/subclass** or **supertype/subtype** relationship, every entity that is a member of a subclass is also a member of the superclass, but in a distinct specific role. The concept of inheritance means that every member of the subclass has its own specific attributes as well as inheriting all the attributes of its superclass. The entity also inherits all the relationships in which the superclass participates.

6.4. Masonry Overall Schema

The geometric and non-geometric masonry unit data are classified and represented in an EER model. We argue that the main data required for MUD can be categorized into the internal and external data to the units. Internal data to the units are represented as *geometry*, *material*, *physical properties*, *color*, and *texture* entities (Figure 4). These entities, along with their associated attributes and the relationship among them are required for activities such as unit specification, comparison, and selection. The external unit data is categorized as *manufacturer*, *supplier* and *project* entities, which are required for business activities such as cost estimation, availability query, and unit of order verification.

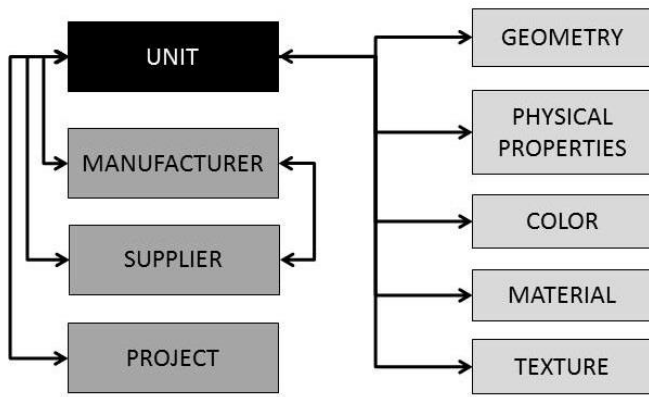

Figure 4: Main masonry unit entities to be represented in the EER model and MUD database.

The complete MUD EER model includes these entities and their associated attributes and the relationship between the entities. Relationships in this model, such as `MADE_BY` relating `UNIT` entity to `MANUFACTURER` entity, define a set of associations that are required for the adequate functionality of the MUD. For example the `DISTRIBUTED_BY` relationship between `UNIT` and `SUPPLIER` entity sets would be utilized in the query of specific masonry unit availability, cost or suppliers' location. The complete network of all MUD entities, attributes, and relationships is represented Figure 5.

6.5. Individual Entities

In this section, each entity and the attributes associated with that entity in the EER model are be described.

6.5.1. Unit

The core of the MUD schema model is the UNIT entity which represents all the masonry units that is going to be represented in this database. There are different attributes that their values define this entity: GUID (Globally Unique ID), name, family name, type, and image and drawing. UNIT entity like all other entities in this model has a GUID attribute that is used for unique identification of each entity in the entity set. Name attribute denotes the commercial name that manufacturers specify for their masonry product. In addition, these units can have a family name that will be used for grouping of a set masonry units with similar characteristics. Type attribute at the high level classifies the masonry products and includes Concrete Masonry Unit (CMU), clay brick and cast stone masonry. The UNIT entity also stores (string) values for images or drawing file locations provided by masonry units manufacturers.

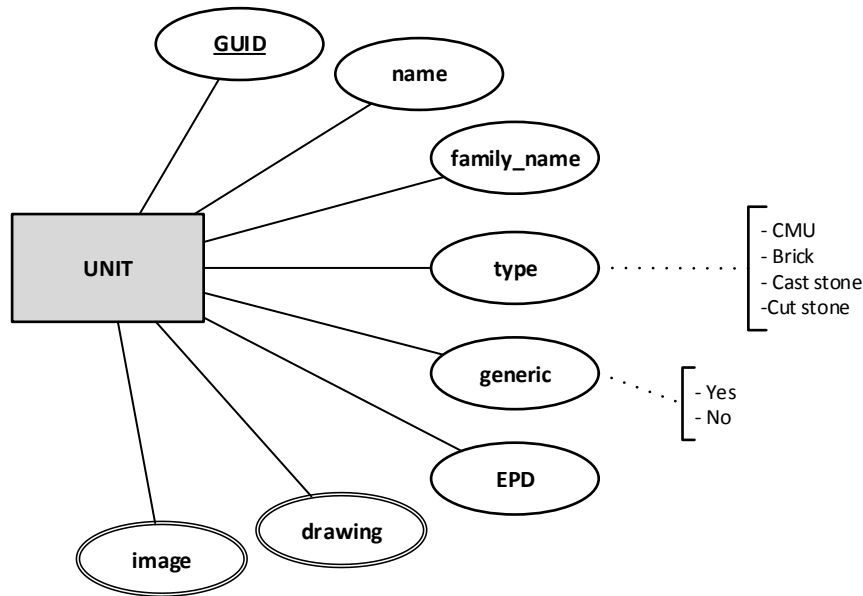

Figure 6. UNIT entity and its attributes.

6.5.2. Geometry

The most substantial entity defined in MUD is GEOMETRY, and the defined entity should be able to represent the geometry of both CMU and clay brick masonry units (Figure 7). The parametric geometry developed for CMU will in many instances be appropriate for structural clay units.

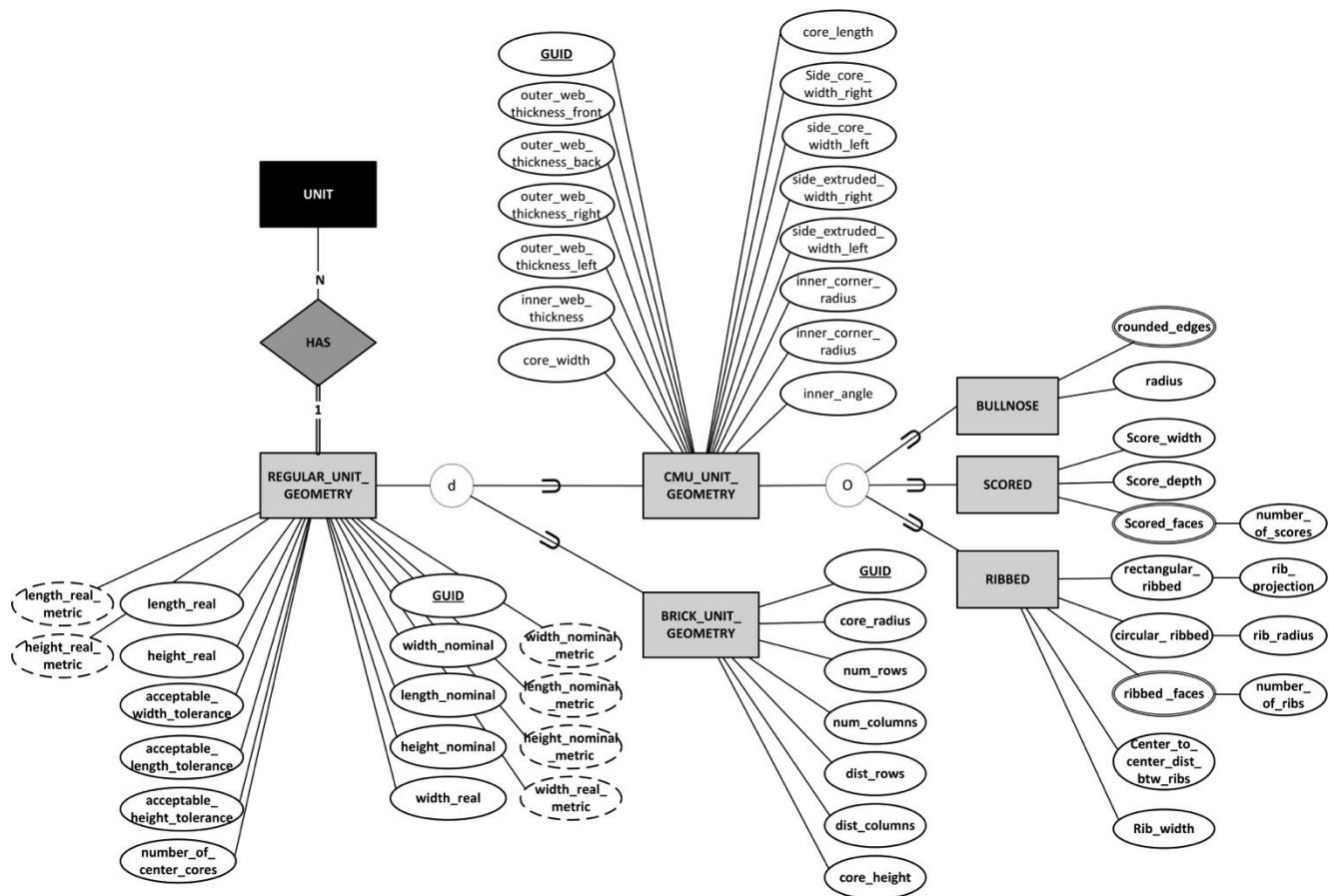

Figure 7. GEOMETRY entity, its subclass entities and their attributes.

For the development of MUD, we classify the units' geometry in three general categories: A) regular masonry unit geometry, B) special masonry unit geometry, and C) custom masonry unit geometry. The regular unit geometry is the major focus of MUD at this stage of development.

The geometry attributes were developed so that a wide range of common units could be represented parametrically as regular units but also so that the database could be easily understood without hundreds of parameters.

A) Regular unit geometry: the geometry of these units can be fully identified and categorized based on their parametric attributes. These units are produced by most masonry manufacturers with almost identical size and shape, although with different tolerances (Figure 8). Based on the assigned values to these attributes, each masonry unit can be identically 3D generated with the stored data in the MUD. CMU general units have parent families including stretcher, pier, corner, return corner, sash, corner sash, bond beam, conduit, lintel, open end, header, starter, and subtype groups such as bullnose, scored, ribbed (circular, rectangular). The clay bricks have two major categories of molded bricks and extruded bricks, and with parent families including thin brick, face brick, structural brick, pavers, etc. For clay units, cores and frogs can be represented as regular units.

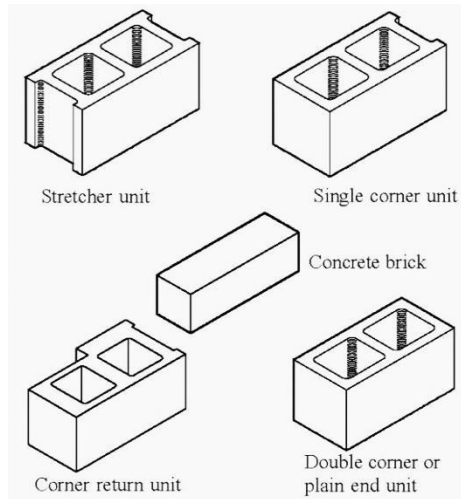

Figure 8. Typical Concrete Masonry Units which can be characterized as “regular” units.

B) Special unit geometry: these units inherit most of the attributes from the regular unit geometry, however they have some special geometric features which are unique to these units. These units are usually produced by one specific manufacturer based on their system of fabrication or particular preferences (Figure 9). Although these units can be partially represented by the parametric attributes that are defined for regular units, defining a set of parametric attributes to cover all their geometric aspects for a complete representation would be impractical, adding extensively to the complexity of the database data model. It will be up to the manufacturer whether they would like to represent their unit as a “special” unit, so that the overall shape and key features can be generated parametrically, or whether they would like to represent the unit as a custom shape.

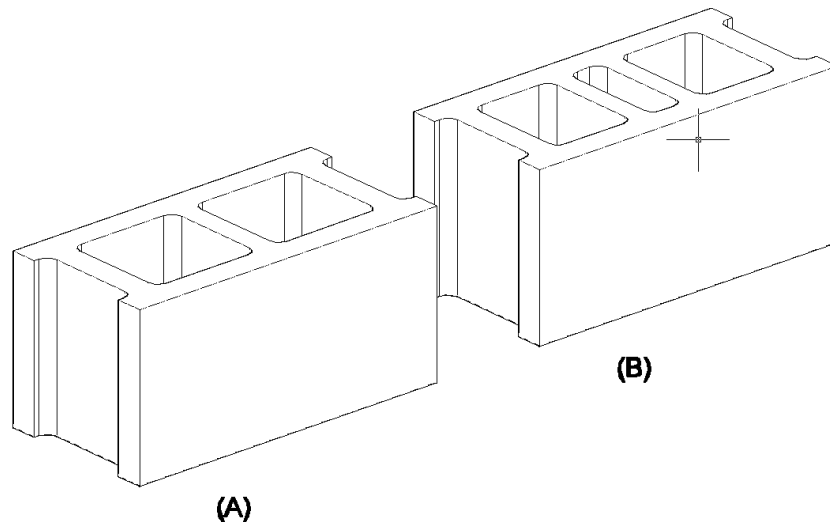

Figure 9. Masonry unit with special geometry (B) can be represented parametrically in the database as a regular unit (A). Non-geometric attributes such as unit weight can be corrected to properly represent the weight of the unit.

C) Custom unit geometry: these units are custom design by the request of the project architect or they are specific to a manufacturer or have such complex geometry that they cannot be represented parametrically (Figure 10). It is likely that many of the cast and cut stone units will ultimately have to be represented as custom units. Their geometry is usually complex and includes almost none of the geometric attributes of the regular masonry units. Geometry of these units is one of a kind, and as a result, parameterizing their geometric features would not be practical. Consequently, these units have to be represented with B-rep (Boundary representation) or CSG (Constructive Solid Geometry) models and to be stored as string data format or 3D files in the database.

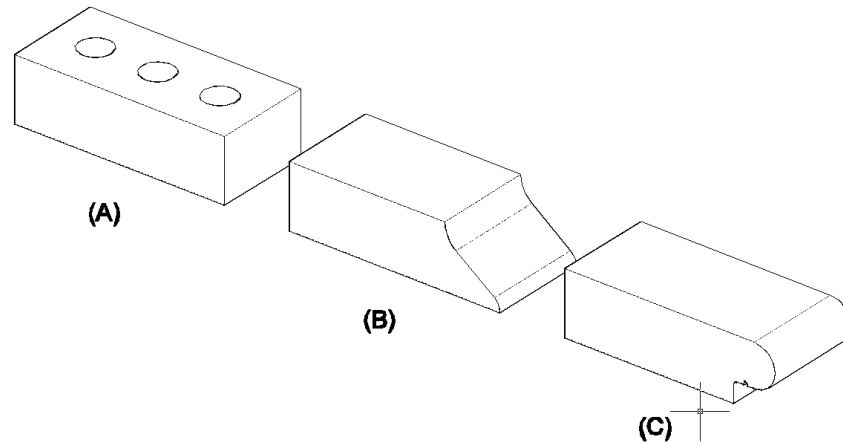

Figure 10. Custom Units (B) and (C) may be accessory units that are related to a regular unit (A).

UNIT Dimensions

Typically, CMU and clay brick units are defined with both nominal and actual dimensions. Nominal dimensions refer to unit size for planning bond patterns and modular layout with respect to door and window openings. Nominal dimensions may vary from the actual dimensions by the thickness of a mortar joint, typically 3/8 inch less than nominal dimensions but not more than 1/2 inch (9 to 12 mm). Actual dimensions refer to the real measured size of a particular unit. The actual dimensions of masonry units are usually 3/8 inch less than nominal dimensions in most masonry units, not accounting for including any adjacent or expected thickness or mortar joints, which is typical for expressions of nominal thickness.

In the US, CMU have nominal face dimensions of 8 in. (20 cm) by 16 in. (40 cm), available in nominal thicknesses of 4, 6, 8, 10, and 12 in. (10, 15, 20, 25, and 30 cm). As actual dimensions are typically 3/8 in. (9) less than nominal dimensions, so that the 4 or 8 in. (102 or 203 mm) module is maintained with 3/8 in. (9.5 mm) mortar joints (Figure 11).

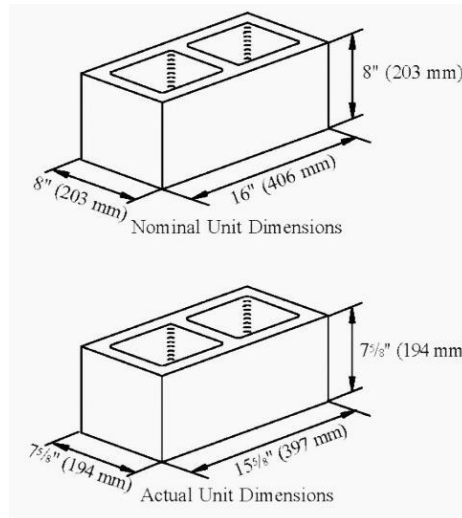
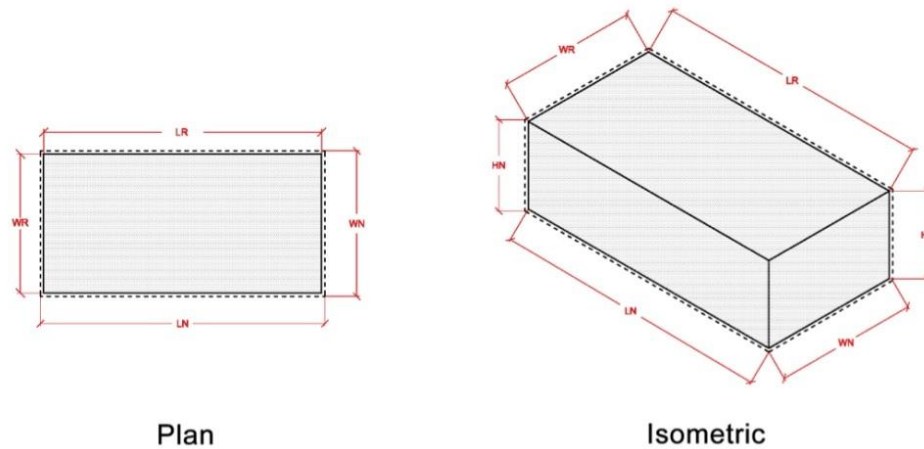

Figure 11. CMU for U.S. markets, nominal and actual unit dimensions. Metric dimensions depict the “soft” metric conversion.

Parametric Geometric Attributes

For the identification of masonry both CMU and clay brick units, we have classified their geometric properties into different attributes. We anticipate that based on these defined attributes all regular geometric units can be adequately represented in the database and regenerated in BIM applications. Because the geometry can be generated parametrically, the storage of the geometry is compact and all of the units do not need to be drawn in CAD. Figures 12A and 12B illustrates these attributes for concrete masonry units. Figure 13 illustrates these attributes for clay brick units.



GUID	Globally unique ID	HR	Height Real
WN	Width nominal	WR_T	acceptable width tolerance
LN	Length nominal	LR_T	acceptable length tolerance
HN	Height Nominal	HR_T	acceptable height tolerance
WR	Width Real	NC_C	Number of Center Cores
LR	Length Real		

Figure 12A. Attributes description, REGULAR_UNIT_GEOMETRY entity.

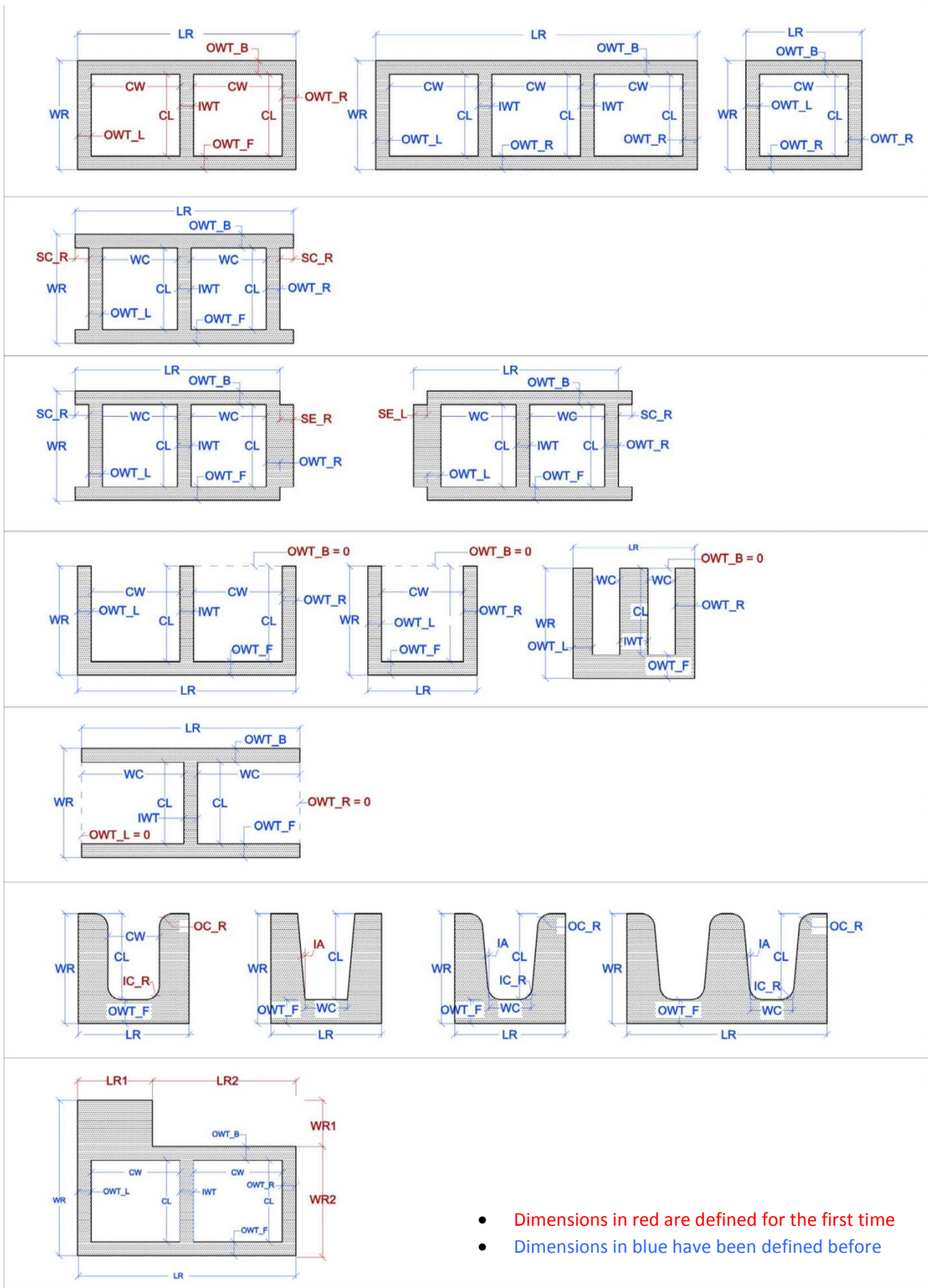

- Dimensions in red are defined for the first time
- Dimensions in blue have been defined before

WR1, WR2	L-Shape blocks	CL	Core Length
LR1, LR2	L-Shape blocks	SC_R	side core - width – right
OWT_F	Outer web thickness Front	SC_L	side core- width - left
OWT_B	Outer web thickness Back	SE_R	side extruded width- right
OWT_R	Outer web thickness Right	SE_L	side extruded width- left
OWT_L	Outer web thickness Left	OC_R	Outer Corner radius
IWT	Inner Web thickness	IC_R	Inner Corner radius
CW	Core width	IA	Inner Angle

Figure 12B. Attributes description, CMU_UNIT_GEOMETRY entity, continued.

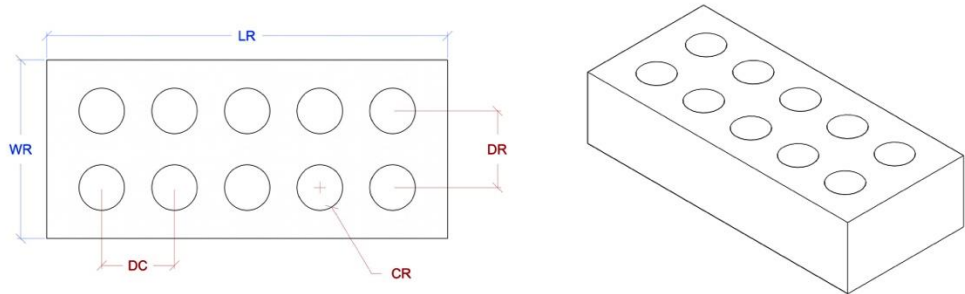

CR	core radius	DC	distance between columns
NC	number of columns	DR	distance between rows
NR	number of rows	CH	core height

Figure 13. Attributes description, BRICK_UNIT_GEOMETRY entity.

6.5.3. Texture

The texture of a masonry unit is an indicator of its appearance, feel, and consistency of a surface. Texture can be defined as the pattern or configuration apparent in an exposed surface of a masonry unit, including roughness, streaking, striation, or departure from flatness. Because the texture is mapped to faces, it is necessary to map the faces and edges of the masonry unit. The convention for doing so is given in Figure 14. Texture applies to both clay and concrete masonry units, but the language used to describe the textures varies depends on the material type. When the database is extended to cast and cut stone, an even more extensive discussion of texture will need to be included. The intent here is to embody both the manufacturer’s description of texture including adjectives like “antique”, “struck”, and “rolled” as well as a numerical scale so that architects can search for units with similar texture. So, for example, searching for a texture amplitude of 1 will return units with absolutely flat surfaces like glazed and ground units. Searching for a texture of 10 will return units with split, slumped and highly irregular faces.

In concrete masonry, texture is closely related to the depth of the natural aggregates and the processes such as machining polish, exposing, buffing the aggregates or glazing that have been applied to the surface of a masonry unit. The attributes that we have defined for the specification of texture entity include texture type, texture family, texture amplitude, and texture measurement (Figure 15). The texture type is consisted of natural texture, processed texture, or glazed coating (where applicable). The texture family for CMU for example includes split-face

(appearance of natural stone, rough-hewn texture with exposed aggregates), ground-face (polished surface finish produced by grinding machine), striated (random striated pattern), etc. The amplitude of the texture indicates the roughness or smoothness of the surface and is measured on the scale of 1 to 10. Measurement attributes could be represented using a quantitative assessment based on the measurement of masonry surface profiles using methods like that provided ASTM D7682, Standard Test Method for Replication and Measurement of Concrete Surface Profiles Using Replica Putty.

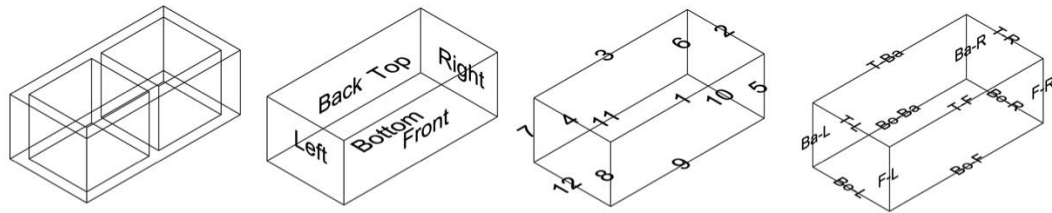

Figure 14. Naming of masonry units faces and edges.

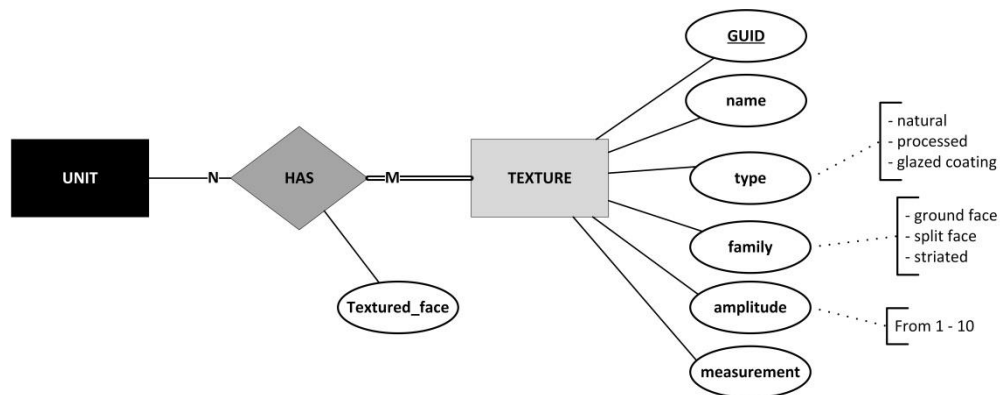

Figure 15. TEXTURE entity and its attributes.

6.5.4. Color

The masonry units color is the result of color ranges in raw materials, aggregate mix, added coloring agents or glazed color in case of glazed bricks. For example the factors that influence color variations in CMU include color variation in pigments, aggregates, cements, clay, water content, degree of compaction achieved during manufacture, and for brick include kiln conditions, changes in clay materials, and atmospheric conditions such as temperature and humidity. Masonry units color variations can be standard or special order. The assign attributes to the Color entity are RGB of the color, color name, and color family (Figure 16). The attribute color family is used to group like units together. Based on discussion with our users, it may be useful to add a second color family, so that a given unit can be identified as belonging to more than one color family (say brown and tan). It is also possible to add a amplitude measurement for “color uniformity”, where a brick with a large amount of color difference would have a low color

uniformity. Again, this is an area where the classification needs to be discussed, particularly with the brick industry.

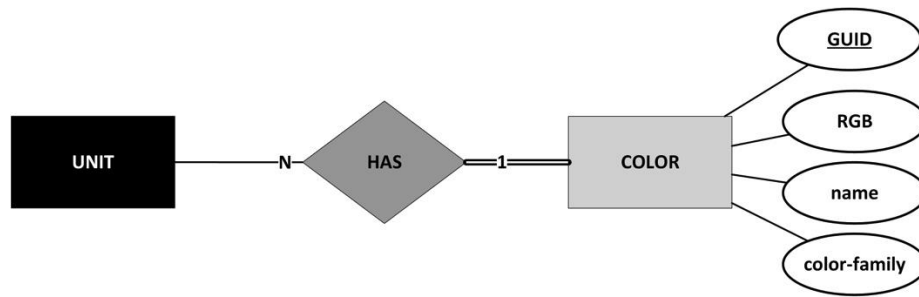

Figure 16. COLOR entity and its attributes.

6.5.5. Physical Properties

The Physical properties entity includes attributes for both mechanical properties and thermal properties of masonry units. These properties are determined based on ASTM (American Society for Testing and Materials) standards for the most part. The physical properties identified for inclusion in the MUD are shown in Figure 17.

It is not possible nor even desirable that the database represent the entire set of physical properties that a masonry unit might have. Instead, what is important is that those properties which are the basis of unit selection are represented (for example, “I need a unit which has a compressive strength greater than 3000 psi”). In the text below, key properties identified by the masonry industry and others identified by our research team are discussed. In addition to facilitating masonry unit selection, relevant properties of units are contained in the database so that the masonry wall models to come in Phase III of the research have sufficient information regarding masonry units, so that physical properties of walls, used for energy and structural analyses.

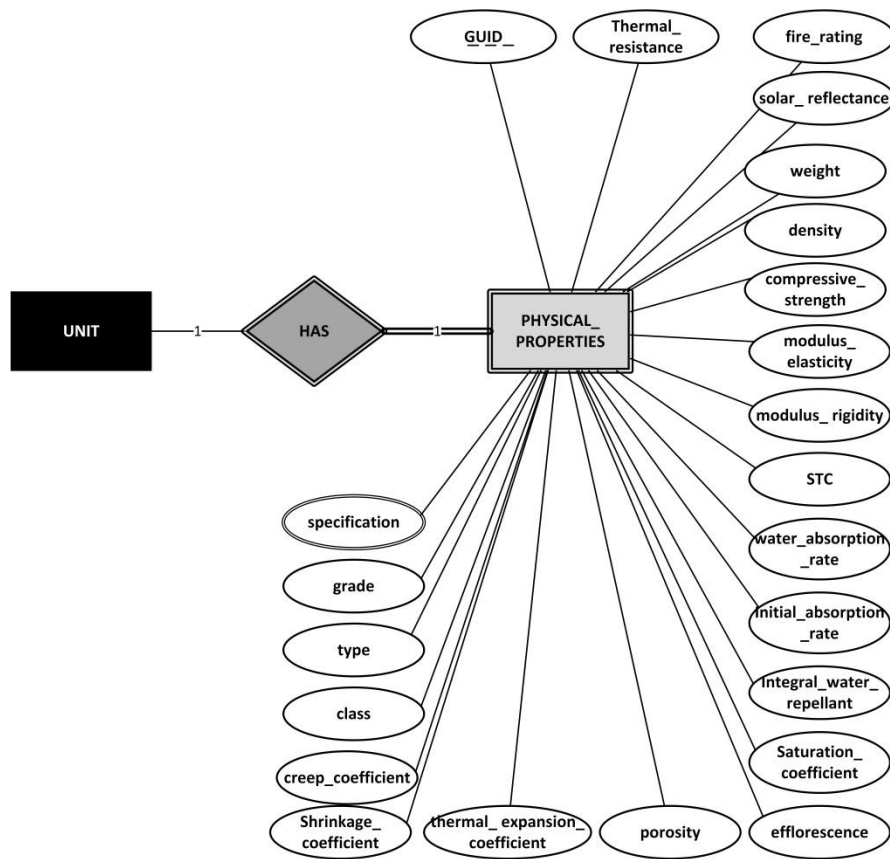

Figure 17. Physical Properties entity and its attributes (thermal and mechanical).

Thermal resistance:

Thermal Resistance or R-Value is the reciprocal of thermal conductivity. Thermal Resistance is correlated to masonry density, since thermal conductivity of material increases with increasing density [h·ft²·°F/BTU] or [K·m²/W]

Fire rating:

Based on building codes, critical building components must have a certain level of fire resistance to protect occupants and to allow a means of escape. Fire resistance rating or fire rating is defined as the duration of time not exceeding 4 hours that a building element, component or assembly maintains the ability to confine a fire, continues to perform a given structural function or both during a standardized test. The rating is not intended to represent actual performance.

Solar reflectance:

Solar reflectance of masonry opaque material is a surface property that is reflectance is measured on a scale of 0 to 1. In this scale, (0) represents not reflective (i.e. flat black) and (1.0) represents a perfectly reflective material surface. In general, light-colored materials have high solar reflectance and dark-colored materials have low solar reflectance.

Weight:

Weight is the specified weight of each unit [pounds] or [Kg].

Density:

Density is a measure of weight per unit of volume of a material or substance. Density can be used to identify a substance [pounds/ft³] or [Kg/m³].

Compressive Strength:

The compressive strength of masonry or $f'm$, is a performance characteristic used by engineers in the design of masonry structures. The strength of masonry units depends on the used raw materials, the manufacturing process and the shape and size of unit. Compressive strength is the maximum compressive force resisted per unit of net cross-sectional area of masonry, and is measured in pounds per square inch.

Modulus of Elasticity (Compressive Strength): The physical measure of a material to deform under the load. It is defined by the “ratio of normal stress to corresponding strain for tensile or compressive stresses below proportional limit of material”. [psi] or [MPa]

Modulus of rigidity (Diagonal Tension or Shear): “ratio of unit shear stress to unit shear strain for unit shear stress below the proportional limit of the material.” [psi] or [MPa]

STC (Sound Transmission Class):

“A single-number rating obtained by classifying the measured values of Sound Transmission Loss in accordance with ASTM Standard E 413 “Classification for Sound Rating Insulations” and TMS 302-12 “Standard Method for Determining the Sound Transmission Class Rating for Masonry Walls”. It provides a quick indication of the performance of a partition for certain common sound insulation problems”. STC ratings is based on weight of the block and whether the cells are filled or not and what material it is filled with if so. The STC number in Masonry Unit Database is based on the STC rating of a hollow masonry unit and we recognize that additional calculations are necessary to derive the STC of an entire wall assembly.

Cold Absorption: (CMU)

Cold absorption is method for concrete units and is tied to ASTM C140 Standard Test Methods for Sampling and Testing Concrete Masonry Units and Related Units. [percent]

Boiled Absorption: (Brick)

The boiled absorption is often used as a measure of brick durability. Brick manufacturers need to clarify whether they would like to have this attribute in the database. [percent]

Water absorption rate: (Brick)

Water absorption rate represents the amount of water that a dry brick unit can absorb in 24 hours period. Water absorption, % by mass, after 24 hours immersion in cold water is given by the formula: (M_1 : weight of dry brick, M_2 : weight of water absorbed brick).

$$W = \frac{M_2 - M_1}{M_1} \times 100$$

Initial Rate of Absorption: (Brick)

The initial rate of absorption (IRA) is the amount of water absorbed in one minute through the bed face of the brick. It is a measure of the brick's 'suction' and can be used as a factor in the design of mortars that will bond strongly with units.

Saturation Coefficient: (Brick)

"The saturation coefficient, also referred to as the C/B ratio, is the ratio of 24-hour cold water absorption to the five-hour boiling absorption" of masonry units. C/B ratio is an indication of the probable resistance of brick to freezing and thawing.

$$\text{Saturation coefficient} = (W_s^2 - W_d) / (W_b^5 - W_d)$$

Integral Water Repellent (IWR):

The integral water repellent is a yes/no attribute for CMU.

Efflorescence Resistance:

Efflorescence is a change on the surface of masonry unit to a powdery substance. This effect is due to the loss of water of crystallization from a hydrated or solvated salt on exposure to air. Efflorescence is usually a white powdery scum, but also can be brown green or yellow, depending on the type of salts in the masonry unit clay, cement or aggregates. This attribute will be defined with a yes/no value in database and actually refers to masonry units which are specifically marketed as "efflorescence resistant". We do not see this across industry product literature so it may not belong in the database.

Porosity:

Porosity or void percentage is a measure of void or empty spaces in the material of masonry units. It is measured by calculating the volume of voids over the total volume of a unit.

(V_V : volume of void-space, V_T : total or bulk volume of material)

$$\phi = \frac{V_V}{V_T}$$

Shrinkage Coefficient: (CMU)

Concrete masonry units shrink over time due to temperature decrease or moisture loss.

$K_m = 0.5 S_L$ (S_L : total linear drying shrinkage of concrete masonry units determined in accordance with ASTM C 426)

Coefficient of Thermal Expansion, CTE:

This is the relationship between change in dimension as it relates to change in temperature. Typically given in units of /°F in U.S. units and /°C in metric units.

Creep Coefficient: (CMU)

Creep is the tendency of material to deform permanently under the influence of long-term exposure to high-level mechanical stress. Creep of concrete in compression is determined in accordance with ASTM C 512)

Classification Attributes Related to Physical Properties

Four additional characteristics of the masonry unit are included as attributes to help differentiate the units based on application. In general, most masonry units meet one or more ASTM Standard Specifications. Within those specifications, there may be types, classes or grades that are related to physical properties of the units. At this time, these four attributes are included. Some brief discussion is included below so that the type of data that should be entered into these fields is clear. The examples given are based on ASTM C652, Standard Specification for Hollow Brick. At this point we believe that CMU are not “graded” according to physical attributes, but rather are specified by size, compressive strength, color, and texture. Therefore, CMU will have a “specification” but the grade, type and class fields will be empty.

Specification:

The standard specifications that masonry unit satisfies (defining the requirements to be satisfied by subject of the ASTM, American Society for Testing and Materials, technical standards). The attribute would be “ASTM C652”.

Grade: (Brick)

Brick grade is the “designation for durability of the unit expressed as SW for severe weathering, MW for moderate weathering, or NW for negligible weathering”. The grade attribute might also be important for concrete masonry units or cast stone – but the SW and MW do not make sense for those materials, as these are terms taken from ASTM C652.

Type: (Brick)

Brick type is the “designation for facing brick which controls tolerance, chippage and distortion, and expressed as FBS, FBX and FBA for solid brick, and HBS, HBX, HBA and HBB for hollow brick”.

Class: (Brick)

Brick type H40V is intended for uses where less void is desired, and type H60V is intended for use where more void is desired.

6.5.6. Material

Masonry units are made of combination of different raw materials created under different processes. CMU is made of a mixture of powdered Portland cement, water, sand, and gravel. Brick is made of natural clay minerals such as kaolin and shale and mixed with small amounts of additive components such as manganese and barium for production of color shades or improvement of chemical resistance. The listing of materials and their percentages is of particular interest on projects where the AEC team is pursuing LEED accreditation or trying to limit the embodied energy in the building.

In MUD, each UNIT is associated with different MATERIAL entities, each of which defined with material name, type, source location and recycled percentage (post-consumer and pre-consumer content) attributes. The relationship between UNIT and MATERIAL represents the percentage of each material used in each specific entity (Figure 18).

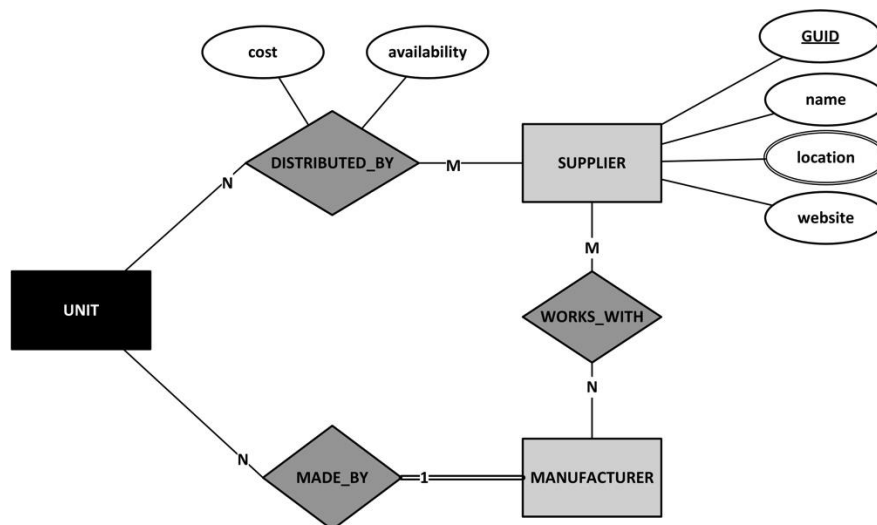

Figure 20: SUPPLIER entity and its attributes.

6.5.9. Project

PROJECT entity represents the building projects that the masonry units have been used in. Each project entity is defined by these attributes: name of the project, owner of the project, and project location.

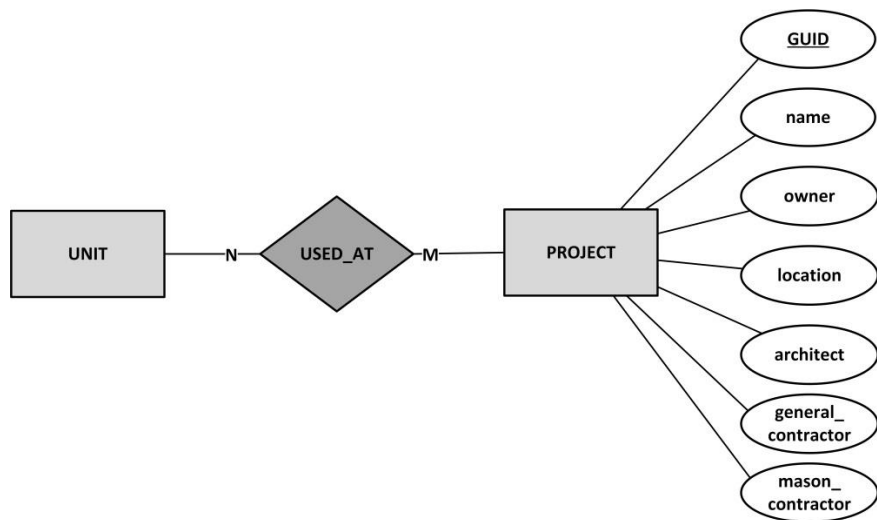

Figure 21: PROJECT entity and its attributes.

7. Industry Review of the Proposed MUD Schema

In the fall of 2014, we intend to implement the database with a small selection of masonry units – in an SQL data management system such as MySQL, and we would like for this database demonstration to be as comprehensive as possible. Therefore, a review of the data model by the current BIM-M community, and especially masonry suppliers and software providers, is critical at this time.

Members of the clay and concrete masonry unit community need to identify additional attributes that should be added to the database – along with the tables in which these attributes belong. The Masonry Supply Working Group (MSWG), under the direction of Jeff Elder, should also review the MUD and see if it meets the specification delivered by the group to us last year. We believe that it does.

Members of the MSWG who typically create custom units as part of their process should review their “top 10” shapes so see how many of their shapes can be classified as “regular” and “special” or “custom” as defined in this document. We recognize that the custom masonry workflow is not fully illustrated in the work of the Georgia Tech team at this time, as the focus has been on regular units. The feedback we need from the cast and cut stone communities is how they could benefit from having their materials in the MUD, even if only a limited selection of all of the possible unit geometries is represented.

Members of the BIM-M software community (who provide software for visualizing, cost-estimating and shop drawing production, for example) need to review the MUD proposed here to see whether and how the data contained in the MUD can support a wider acceptance of their products. They should comment on the translation required to map the generic data formats described here to the internal formats used in their software. The same review and feedback will be requested of the major BIM product portal providers. If data needs to be added to the MUD to support its implementation into product portals, we need to update the MUD schema to support these data sources.

Georgia Tech has is developing short presentations to accompany this report. A webinar has been scheduled in August to begin presenting this information to the masonry supply community, so that we can begin to actively solicit their feedback.

Appendix 1

The appendix below contains the relational database schema for the MUD. This is essentially an alternative view into the database from that provided in Section 6 but it shows clearly the relationship between the tables.

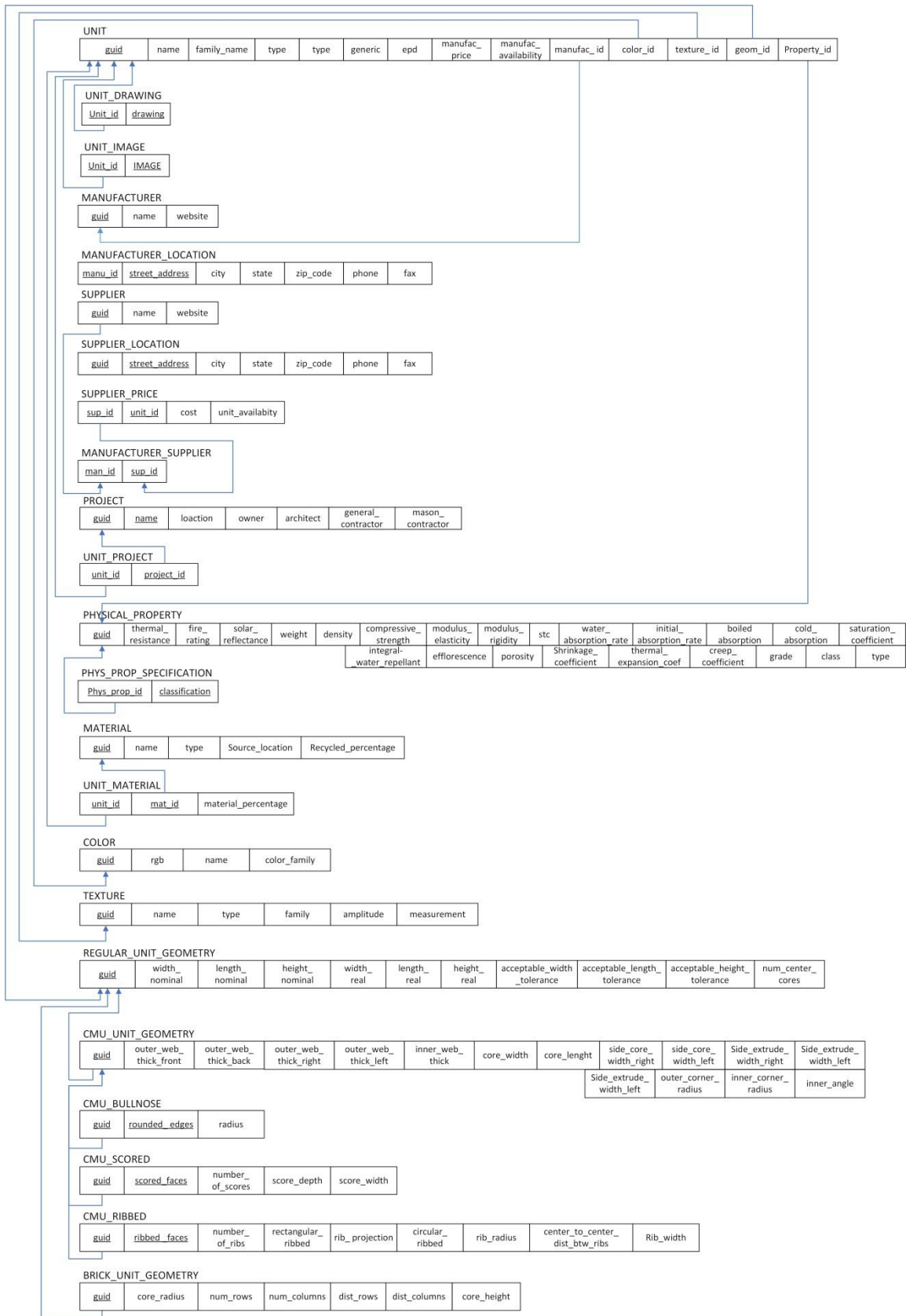

Figure 22. Masonry Unit Database relational database schema.

Relational Database Tables in the MUD

CREATE TABLE UNIT

(u_id	INT	NOT NULL,
u_name	VARCHAR (30)	NOT NULL,
cost	DECIMAL (10,5)	NULL,
availability	INT	NULL,
manufac_name	VARCHAR (50)	NOT NULL,
color_rgb	INT	NOT NULL,
texture_name	VARCHAR (100)	NOT NULL,
geom_id	INT	NOT NULL,
Property_id	INT	NOT NULL,

PRIMARY KEY (u_id),

FOREIGN KEY (manufac_name) **REFERENCES** MANUFACTURER (m_name),

FOREIGN KEY (color_rgb) **REFERENCES** COLOR (rgb),

FOREIGN KEY (texture_name) **REFERENCES** TEXTURE (t_name),

FOREIGN KEY (geom_id) **REFERENCES** GEOMETRY (g_id),

FOREIGN KEY (property_id) **REFERENCES** PHYSICAL_PROPERTIES (p_id));

CREATE TABLE MANUFACTURER

(m_name	VARCHAR (50)	NOT NULL,
street_address	VARCHAR (200)	NOT NULL,
city	CHAR (30)	NOT NULL,
state	CHAR(2)	NOT NULL,
zip_code	INT	NOT NULL,
phone	INT	NULL,
fax	INT	NULL,
website	VARCHAR (30)	NULL,

PRIMARY KEY (name));

CREATE TABLE PROJECT

(p_name	VARCHAR (30)	NOT NULL,
address	DECIMAL (10,5)	NOT NULL,
owner	DECIMAL (10,5)	NOT NULL,

PRIMARY KEY UNIT (u_id));

CREATE TABLE UNIT_PROJECT

(unit_id	INT	NOT NULL,
Project_name	VARCHAR (30)	NOT NULL,

PRIMARY KEY UNIT (unit_id, Project_name),

FOREIGN KEY (unit_id) **REFERENCES** UNIT (u_id),

FOREIGN KEY (project_name) **REFERENCES** PROJECT (p_name));

CREATE TABLE PHYSICAL_PROPERTIES

(p_id	INT	NOT NULL,
fire_rating	DECIMAL (10,5)	NULL,
Solar_reflectance	DECIMAL (10,5)	NULL,
Stc	DECIMAL (10,5)	NULL,
thermal_resistance	DECIMAL (10,5)	NULL,
density	DECIMAL (10,5)	NULL,
Strength	DECIMAL (10,5)	NULL,
Modulus	DECIMAL (10,5)	NULL,
Rupture_strength	DECIMAL (10,5)	NULL,

Tension_strength DECIMAL (10,5) NULL,
PRIMARY KEY UNIT (p_id));

CREATE TABLE MATERIAL

(m_name VARCHAR (100) NOT NULL,
type VARCHAR (100) NOT NULL,
Source_location VARCHAR (100) NOT NULL,
Recycled_percentage DECIMAL (2,2) NULL,
PRIMARY KEY UNIT (m_name));

CREATE TABLE UNIT_MATERIAL

(unit_id INT NOT NULL,
mat_name VARCHAR (100) NOT NULL,
Material_percentage DECIMAL (2,2) NULL,
PRIMARY KEY UNIT (unit_id, mat_name),
FOREIGN KEY (unit_id) **REFERENCES** UNIT (u_id),
FOREIGN KEY (mat_name) **REFERENCES** U MATERIAL (u m_name));

CREATE TABLE COLOR

(rgb INT NOT NULL,
name VARCHAR (30) NULL,
color_family VARCHAR (30) NULL,
PRIMARY KEY UNIT (rgb));

CREATE TABLE TEXTURE

(t_name VARCHAR (100) NOT NULL,
type VARCHAR (100) NOT NULL,
PRIMARY KEY UNIT (t_name));

CREATE TABLE GEOMETRY

(g_id INT NOT NULL,
With_nominal DECIMAL (10,5) NOT NULL,
Length_nominal DECIMAL (10,5) NOT NULL,
Height_nominal DECIMAL (10,5) NOT NULL,
Width_real DECIMAL (10,5) NOT NULL,
Length_real DECIMAL (10,5) NOT NULL,
Height_real DECIMAL (10,5) NOT NULL,
Acceptable_width_tolerance DECIMAL (10,5) NULL,
Acceptable_length_tolerance DECIMAL (10,5) NULL,
Acceptable_height_tolerance DECIMAL (10,5) NULL,
Num_cent_cores DECIMAL (10,5) NOT NULL,
Outer_web_thick_front DECIMAL (10,5) NOT NULL,
Outer_web_thick_back DECIMAL (10,5) NOT NULL,
Outer_web_thick_right DECIMAL (10,5) NOT NULL,
Outer_web_thick_left DECIMAL (10,5) NOT NULL,
inner_web_thick DECIMAL (10,5) NULL,
core_width DECIMAL (10,5) NULL,
core_lenght DECIMAL (10,5) NULL,
Side_core_width_right DECIMAL (10,5) NULL,
Side_core_width_left DECIMAL (10,5) NULL,
Side_extrude_width_right DECIMAL (10,5) NULL,
Side_extrude_width_left DECIMAL (10,5) NULL,
Side_extrude_width_left DECIMAL (10,5) NULL,
outer_corner_radius DECIMAL (10,5) NULL,
inner_corner_radius DECIMAL (10,5) NULL,

inner_angle DECIMAL (10,5) NULL,
PRIMARY KEY UNIT (g_id));